

**The Canterbury J Class (One Design) Owners'  
Association Inc.**

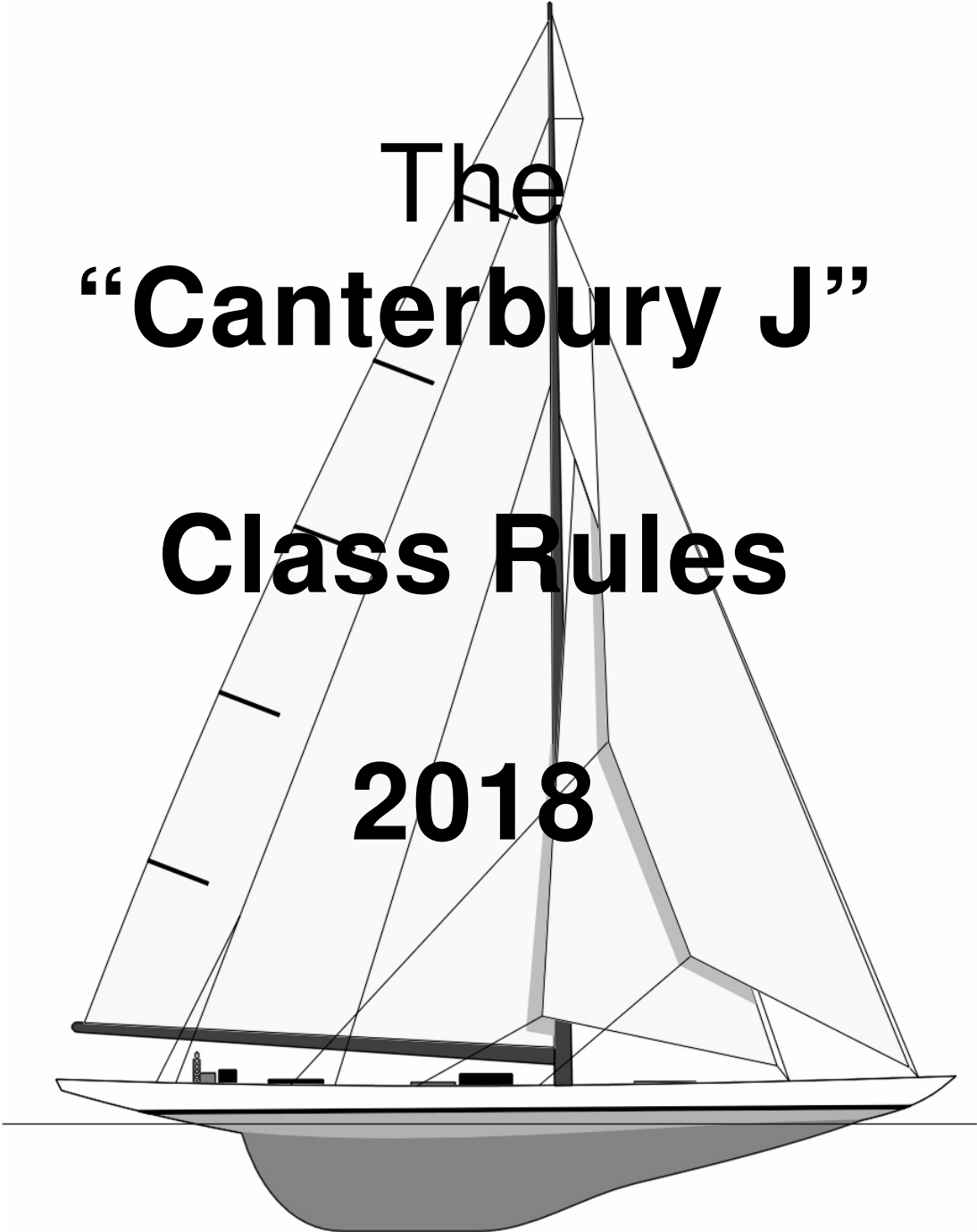

**The  
“Canterbury J”  
Class Rules  
2018**

**As Accepted 2000.**

**Revised October 2010.  
Revised October 2014  
Revised October 2016  
Update February 2018**

**Revised February 2014.  
Revised October 2015  
Revised October 2017**

# THE CANTERBURY J CLASS

## RESTRICTED DESIGN RADIO CONTROLLED MODEL YACHT

### CLASS RULES

#### 1) GENERAL

1.1 The design is based on the full sized "J" class yacht Ranger with design changes to provide a model with good sailing abilities that is easily controlled by radio. The rules serve to control the parameters of construction to allow for racing between boats of similar speed and characteristics. Material specifications and methods of construction are controlled with the intention of encouraging home building and keeping the class affordable to a large range of people. It is intended that the rules of the class shall remain unchanged over time to ensure that all boats are able to retain a competitive position within the class and thus hold their value.

1.2 Terminology: In these Rules the word "shall" and "will" means the pertinent rule must be strictly adhered to. The word "may" means that this is optional.

1.3 The Class shall consist of a fiberglass hull from the Class Association's official mould(s), a lead keel and trim weight from an approved mould(s), a rudder as per specifications, and rigs as per the sail plans with rigging that falls within the specifications. A bow bumper of a type approved by the Measurer shall be fitted and is not to be included within the overall length. Radio control is constrained to the use of two channels, being one rudder control and one coupled jib/main sail sheeting control.

#### 2) HULL, KEEL, TRIM WEIGHT AND RUDDER

2.1 The hull (shell) is a one piece moulding of glass reinforced polyester resin produced in the official mould(s). No fibers or cloth other than glass shall be used as a reinforcement of any resins used for completing the construction of the hull shell including its deck and rudder blade, but excluding any hull fittings that can be attached and detached from it. The registered hull number label is to be glassed into the interior of the hull in such a position that it can be seen by the measurer when certificated.

##### 2.2 **Dimensions of the hull.**

All measurements shall be taken from the outside of the fiberglass hull shell and shall exclude any protective strips or belting around the gunwales. If used, these shall have a maximum thickness of 3mm external to the hull shell.

Maximum overall length: 1220 mm  
Beams as measured from the bow:  
at quarter length (305 mm): 145 -150 mm  
at half length (610 mm): 215 -220 mm  
at three quarter length (915 mm): 185 -190 mm

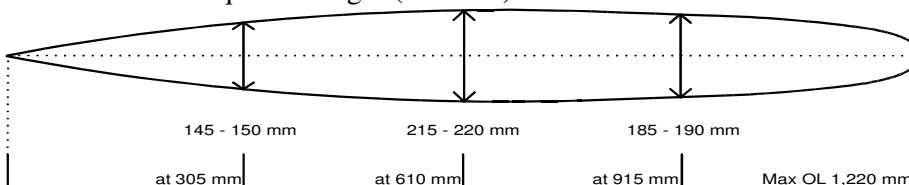

### 2.3 Appendages.

No appendages shall be attached externally to the boat which extend beyond or below the gunwale, excepting;

- a a bow bumper
- b attachments for the backstay
- c the rudder and its lower support.

2.4 The keel and trim weight shall be produced only from the Class Associations official mould(s) or others approved by the Association. No materials other than lead shall be used.

2.5 The keel shall be bolted flush to the bottom of the keel stub and may be prepared and filled to provide a smooth underwater finish. If the supplied keel should be larger than the hull shell profile, it shall be reduced in size to conform to the hull shell. No altering of the hull shell is allowed. No other additional weight or spacers shall be inserted between the keel stub and the keel. No additional weight in any form shall be inserted internally between the keel stub and the wooden floor.

2.6 The dimension of the stern post back edge shall be a maximum of 215mm. This shall be measured along the stern post from; the lower edge of the keel (lower rudder support included) to the intersecting lines of the hull.

2.7 The trim weight shall have a fixing hole of 8mm diameter centred 40mm (plus or minus 3mm) from the wider end and central between either edges. It shall be bolted onto the front keel bolt and lie flat on the wooden floor with the tapered end facing forward and shall be visible and accessible for inspection. Fittings may be attached to the trim weight. It shall not otherwise be altered from its original supplied state.

2.8 The weight of the complete boat with mast, booms, rigging, sails, and radio gear, including batteries, of a type and size normally used in radio controlled yachts, shall not be less than 6.500 kg when carrying the "A" rig as per the measurement diagrams.

2.9 The Rudder profile shall not exceed the official pattern (see relevant page for pattern) the rudder post shall be included within this area for measurement purposes.  
No fairing between the top of the rudder and the hull or between the keel and the leading edge of the rudder is permitted. The rudder thickness shall not exceed 15mm.  
The rudder shall not be ballasted.

2.10 The rudder may be mounted using a lower fitting and shall lie parallel with the stern post with a gap not exceeding 4mm. The rudder lower fitting shall be no wider than the keel width at the attachment point.

## 3) **RIG**

3.1 A rig is defined as a mast, a mainsail and its boom, a jib with its boom, all with permitted fittings and rigging.

### 3.2 Masts

3.2.1 Masts shall comply with the measurement specifications in these rules. The basic mast section shall be constructed of either aluminium alloy or wood. No other materials will be allowed.  
Fittings however may be of other materials.

3.2.2 Masts may be stepped on or through the deck.

- 3.2.3 Mast stubs shall be permitted.
- 3.2.4 Measurement bands in a colour that contrasts with the mast shall be displayed as per the sail and mast diagram and chart.
- 3.2.5 Above the lower band 1, masts shall be of constant external circular diameter, without grooves for internal sail tracks. All fittings, holes, slots etc shall be ignored when considering the requirements of diameter. Internal stiffening and joining sleeves are permitted.
- 3.2.6 The centre of the mast / mast stub shall pass through the deck between points 490 -540 mm from the bow. The centre of deck stepped masts shall also be positioned between these two points on the deck.
- 3.2.7 For the purposes of measurement the deck level shall be measured from a straight line between the gunwales at a distance of 530 mm from the bow.

**3.3 Fittings:** Each mast may have:

- 3.3.1 One wind vane.
- 3.3.2 One back stay crane to extend the fixing position of the backstay to the mast head beyond the allowed roach of the mainsail.
- 3.3.3 Attachments for jib stay or halyard and shrouds.
- 3.3.4 One set of spreaders and their attachments.
- 3.3.5 Attachments for the mainsail luff, head, and tack.
- 3.3.6 Below the lower band 1, any fitting or system may be used to step, support or control the position of the mast or boom.
- 3.3.7 A gooseneck fitting and its attachments. No ball raced fittings will be permitted.
- 3.3.8 A kicking strap and its attachments. This may be combined with the gooseneck fitting.
- 3.3.9 A fitting or system to mount the mast on the mast step.

**4) STANDING RIGGING**

4.1 Masts shall be supported by:

- 4.1.1 Jib stay and/or jib halyard shall intersect the mast below band 2. Forestays of a rigid type will not be permitted.

- 4.1.2 One pair of shrouds with optional inner lower stays. Spreaders will be permitted but shall be restricted to one set on each mast.

- 4.1.3 One backstay which may be split into a two part bridle no higher than 300 mm above the deck to allow for tensioning adjustment if desired.

## 5) **BOOMS**

- 5.1.1 Construction: Booms shall be aluminium alloy, carbon fibre tube or wood and of a constant external circular diameter excluding fittings. Internal sail tracks shall not be permitted.
- 5.1.2 Main boom fittings: Each main boom may have:
- i) Attachments for tack, sheet, and clew.
  - ii) Kicking strap.
  - iii) A gooseneck fitting of any type or style, excluding ball-raced fittings
- 5.1.3 Jib boom fittings: Each jib boom may have:
- i) Attachments for jib stay, tack, sheet, clew, and topping lift.
  - ii) A Boom swivel.
  - iii) Counterweight which shall not extend beyond the bow when measured on the centre line.

## 6) **SAILS**

Sail dimensions shall be restricted to the three rigs A, B, and C as shown in the Measurement Diagram in these Rules.

- 6.1.1 Sails may be made of any material.
- 6.1.2 Sails shall comply with the dimensions given in the Measurement diagram in these Rules (see page 13).
- 6.1.3 During measurement sail battens need not be removed and sails may remain attached to the spars.
- 6.1.4 The same sail material and weight shall be used throughout the body of each sail.
- 6.1.5 Seams, including reinforcements and tabling, shall not exceed 15 mm in width.
- 6.1.6 Corner reinforcements shall not exceed 125 mm in any direction when measured from the corner measurement point.
- 6.1.7 Telltales may be fitted to mainsails and to jibs.

### **6.2 Mainsails**

- 6.2.1 Each mainsail shall be made of a maximum of four panels joined by seams which shall not be closer than 150 mm to a corner. No pleat, cut or tuck shall be permitted on any panel.
- 6.2.2 Any method of attachment of sails to the mast is permitted with the

exception of an internal grooved sail track.

- 6.2.3 The leech or foot of the sail shall not be convex between measurement points.
- 6.2.4 There may be up to three battens supporting the leach. Each batten shall be fixed within 3 mm of each measurement point on the sail leach. The top batten shall not exceed 75 mm in length and the other two battens shall not exceed 100 mm in length.
- 6.2.5 No part of the mainsail shall extend beyond the lower edge of the upper mast measurement band 3 or the upper edge of the lower mast measurement band 1.

### **6.3 Jibs**

- 6.3.1 Each jib shall be made with a maximum of three panels joined by seams that shall be no closer than 100 mm to the corner measurement point. No pleat, cut or tuck shall be permitted on any panel.
- 6.3.2 The luff tabling may envelope the jib stay and a luff tube may be fitted provided that no support against forestay sag is gained by the fitting of such a tube.
- 6.3.3 The jib leach shall not extend outside a straight line drawn from the clew measurement point to a point 20 mm aft from the upper measurement point.
- 6.3.4 If used the maximum number of battens to support the jib leach shall be two and their positioning on the leach is optional. There may be only one batten if desired. The battens shall not exceed 75 mm in length.

7) **CLASS INSIGNIA, SAIL NUMBERS and NATIONAL LETTERS.**

**7.1 Class Insignia**

7.2.1 The class insignia shall be displayed in accordance with Appendix E, Radio Sailing Racing Rules.

7.2.2 The placement is between 150mm and 450mm from the main sail head.

7.2.3 The class insignia is the letter “J” as the example and details below.



*Font Helvetica / Arial and 60 mm in height*

**7.2 Sail Numbering.**

7.2.1 Sail numbers shall be the hull number up to and including the last three digits of the hull number and displayed in accordance with Appendix E, Radio Sailing Racing Rules. The requirement to allow for a prefix or suffix shall not Apply.

**7.3 National Letters**

7.3.1 National letters shall be displayed in accordance with Appendix E, Radio Sailing Racing Rules, but is not compulsory.

**(refer to Supplementary sheets for class insignia, sail numbering and national letter detail)**

**8) Measuring**

8.1 Any alterations or replacements shall be subject to the current class rules.

8.2 Any rule changes made at an AGM shall by default allow old boats with a current measurement certificate to continue with full recognition of said certification. (The Grandfather Clause)

At the AGM where a new rule is introduced and accepted, the Grandfather clause may be over ridden by a vote of 2/3<sup>rd</sup> majority of attendees.



RUDDER TEMPLATE (as close to maximum size as possible, printing may distort).

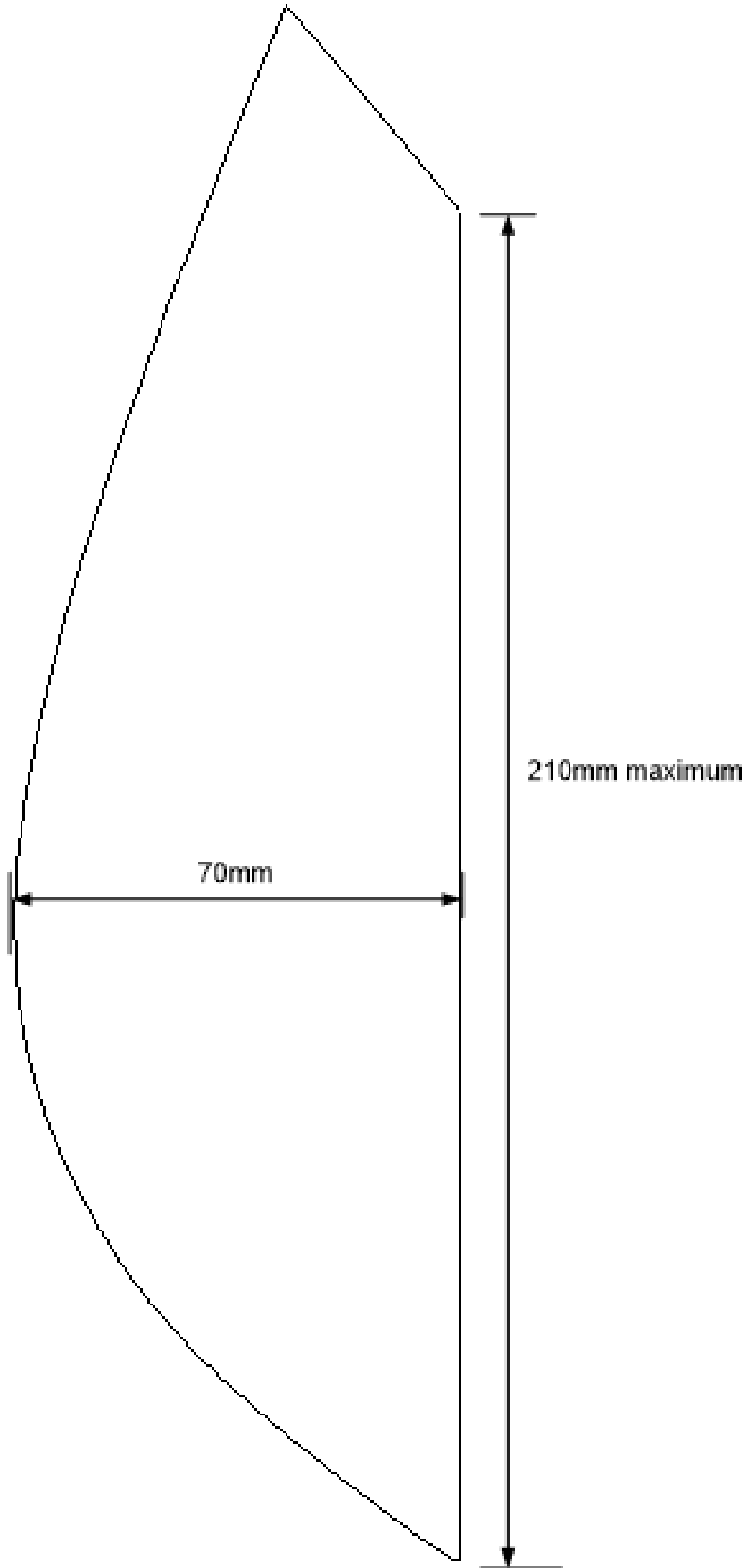

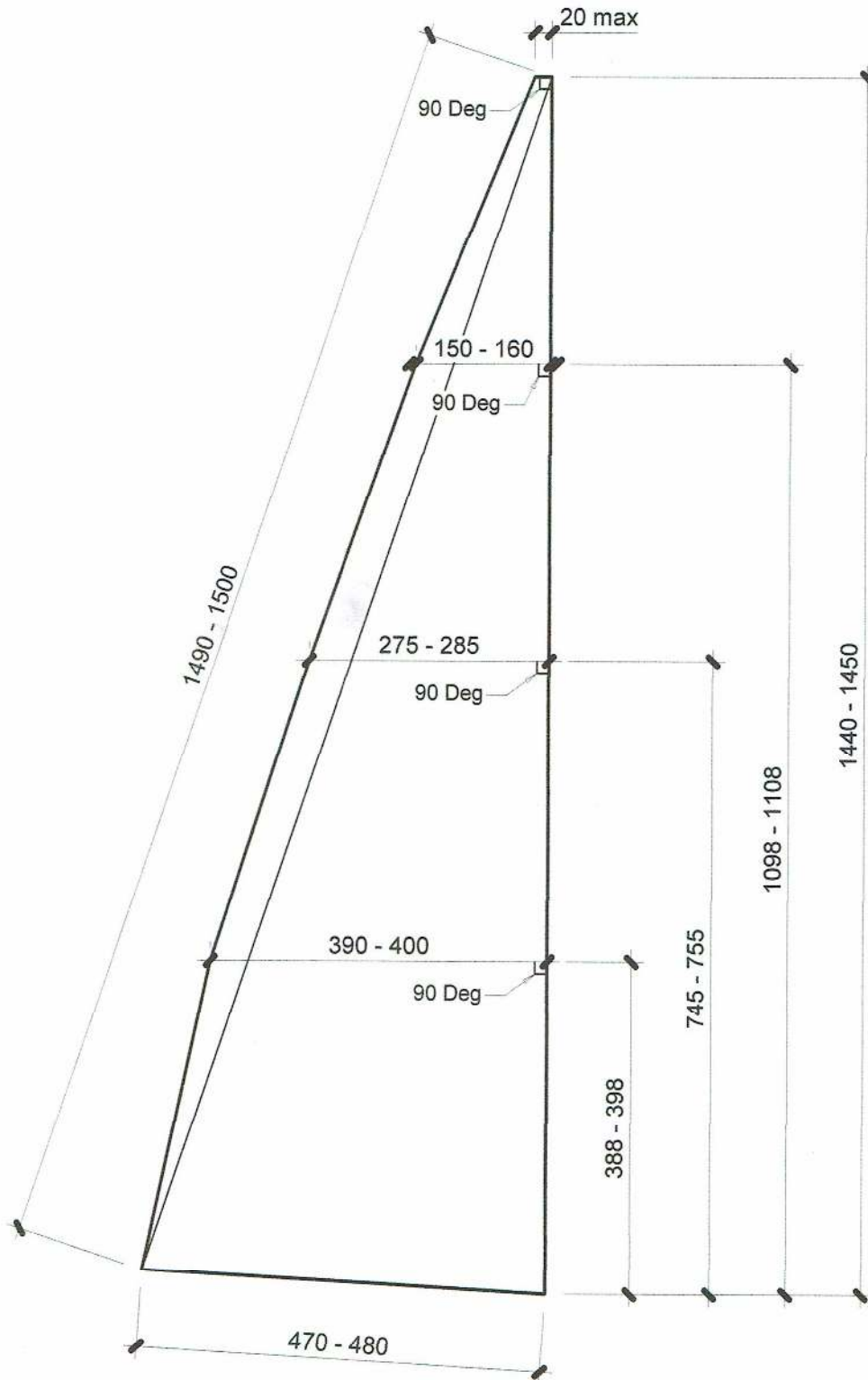

J Class Yacht A Rig Mainsail Plan

9 Nov 2016

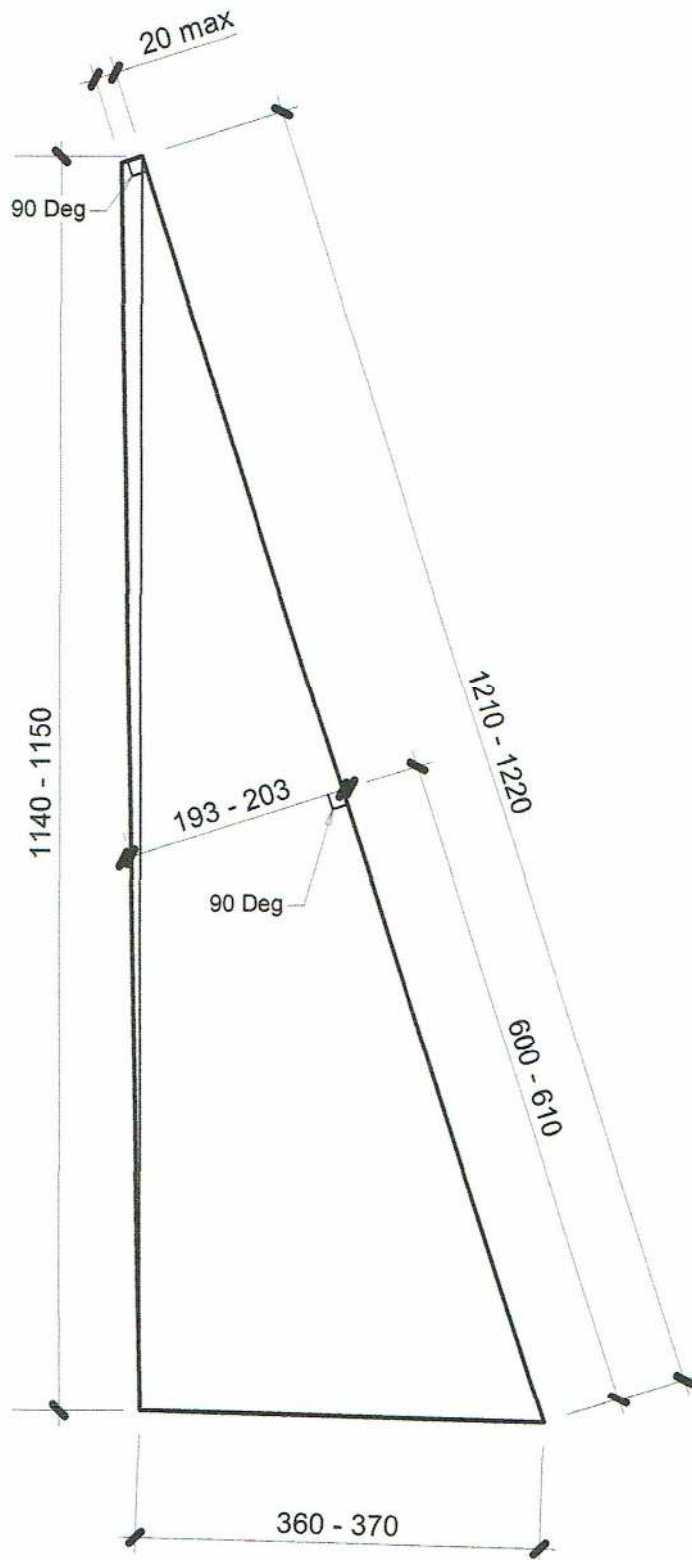

J Class Yacht A Rig Jib Sail Plan

19 Oct 2016

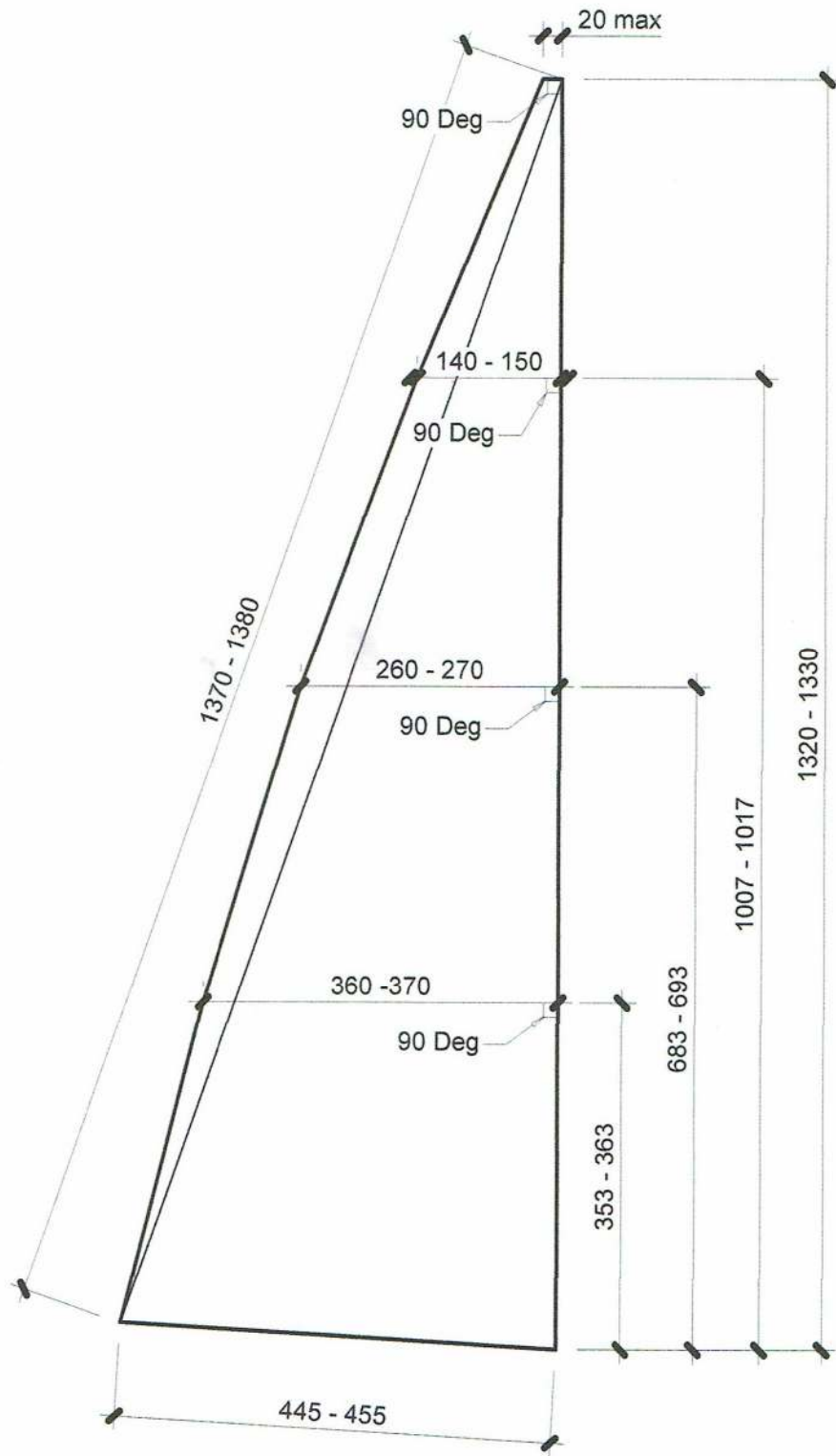

J Class Yacht B Rig Mainsail Plan

9 Nov 2016

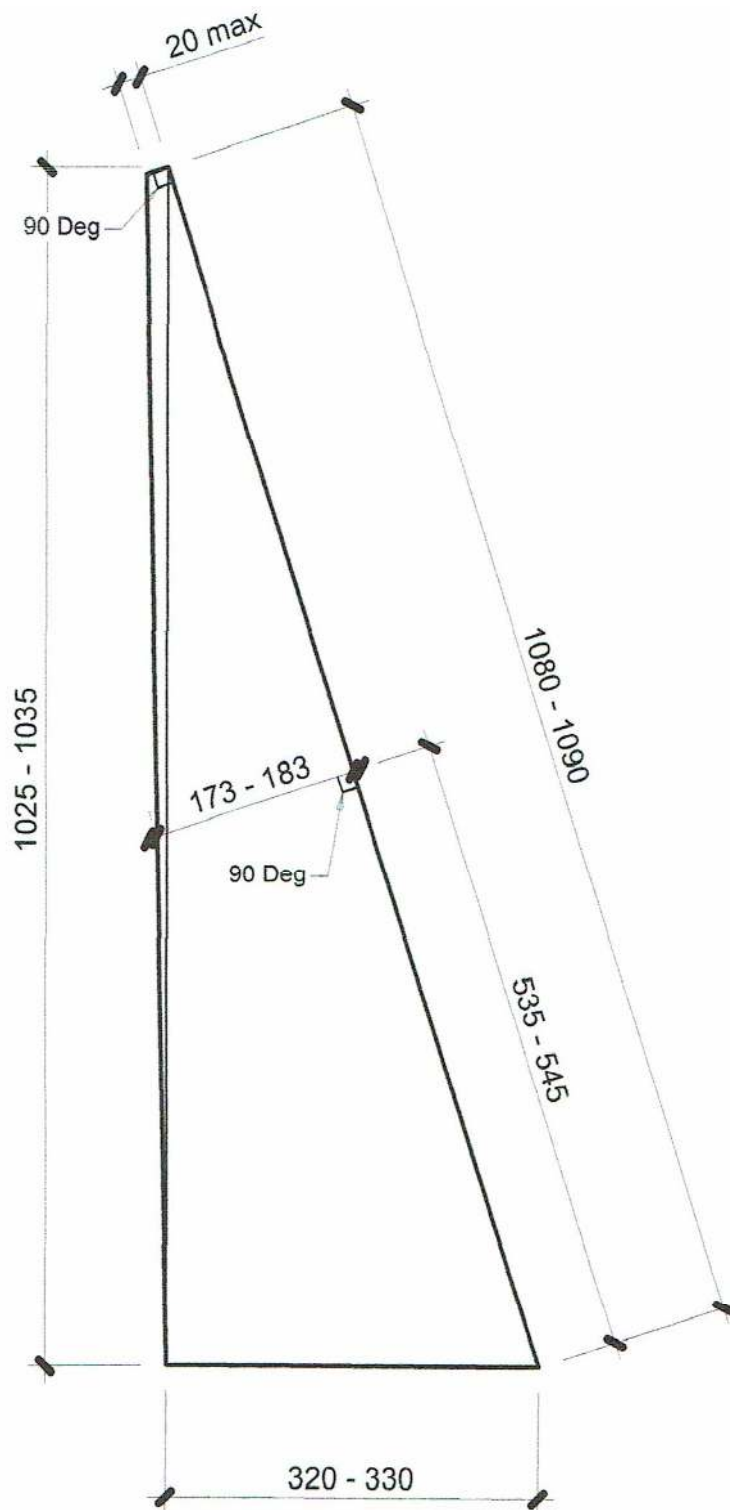

# J Class Yacht B Rigjib Sail Plan

25 Oct 2016

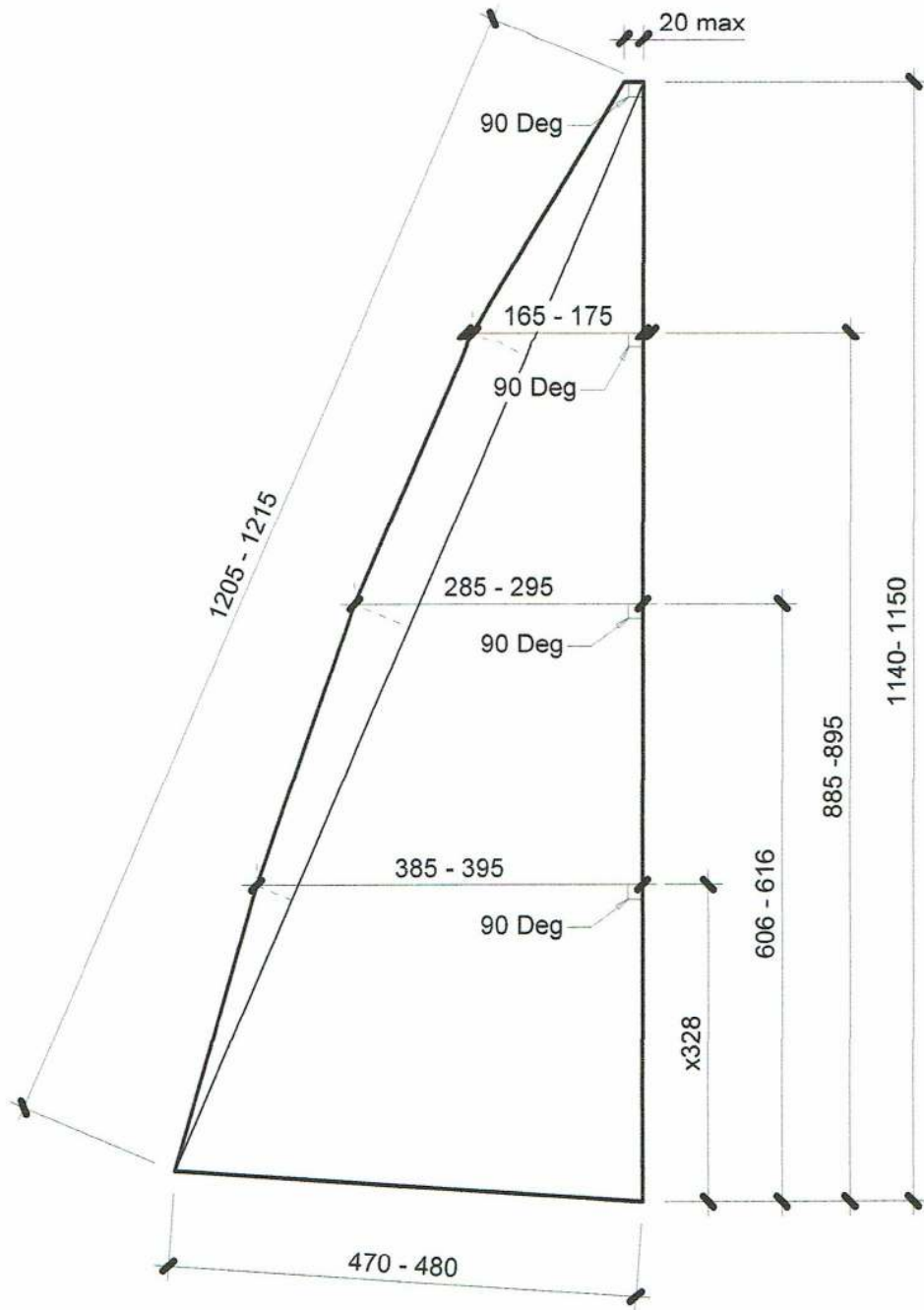

J Class Yacht C Rig Mainsail Plan

26 Oct 2016

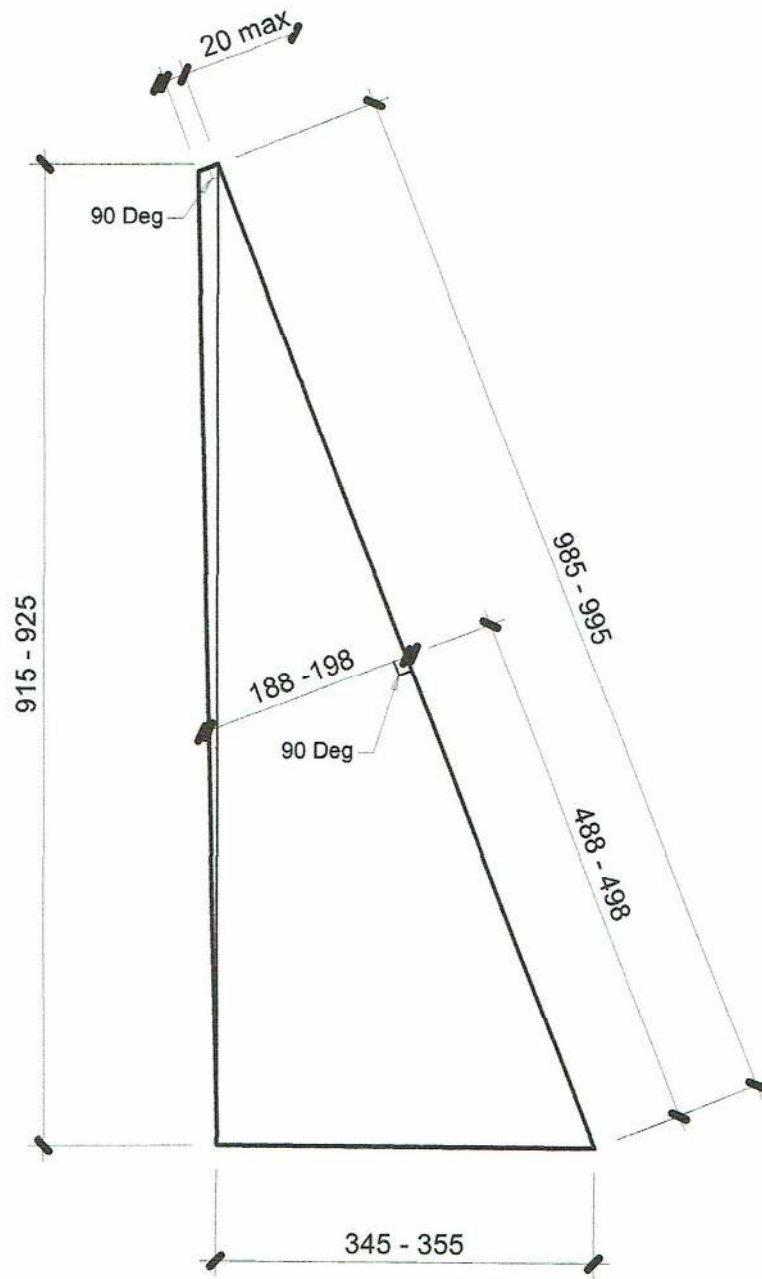

J Class Yacht C Rig Jib Sail Plan

4 Nov 2016

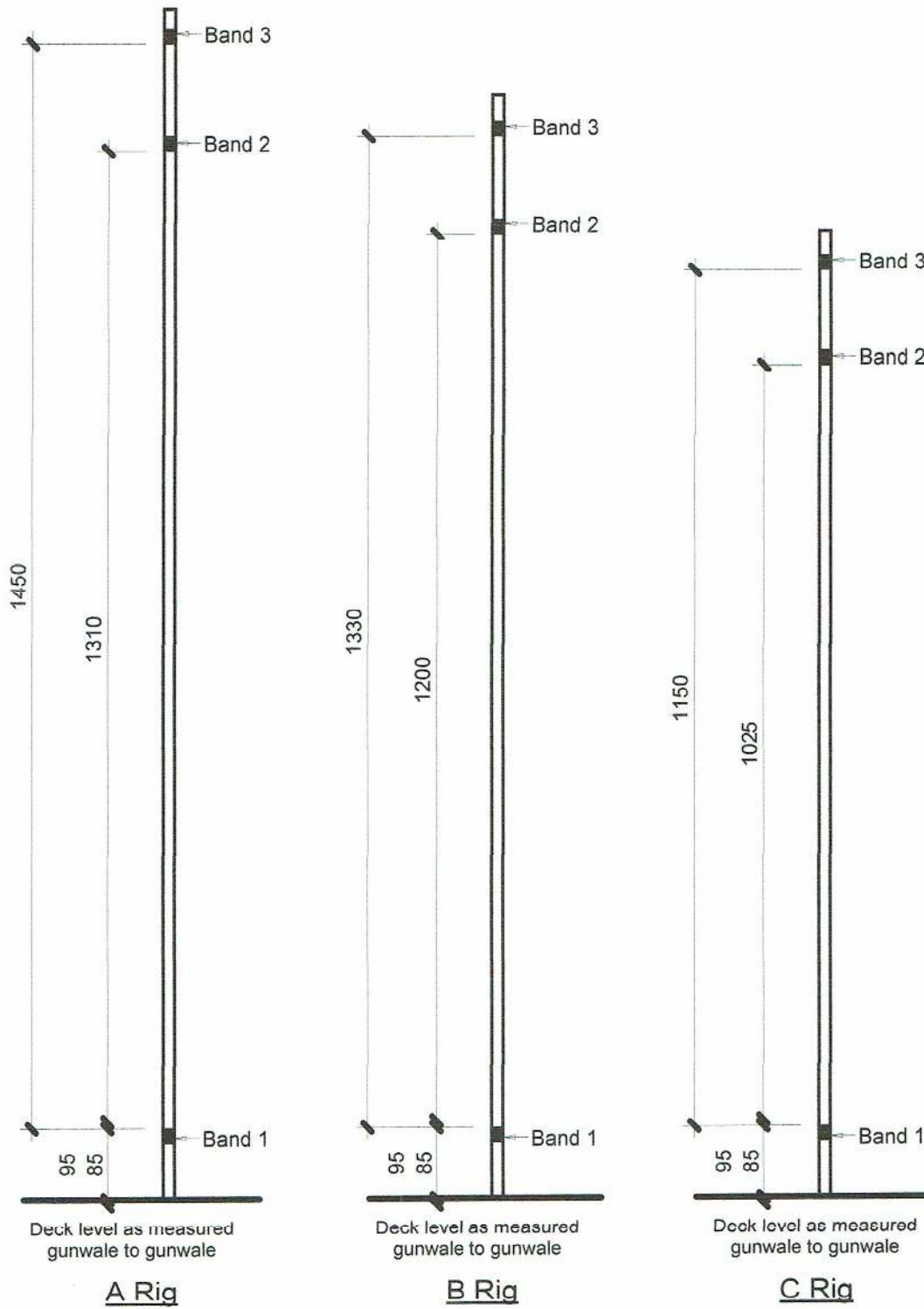

**J Class Yacht A, B & C Rig  
Mast Band Details**

*All dimensions in mm*

4 Nov 2016



## NOTES AND AMMENDMENTS

### 1) November 2004

From the Annual General Meeting of October 30th 2004 - General Business 5: -

**Bow Bumpers** - Following on from the Minutes it was passed that the Class Rules 1.2 be amended as follows:-

"That the Class Rules be added to, in order to show the fitting of a Bow Bumper on the Canterbury J Class be made mandatory. Such a bumper is to be a minimum of ten millimetres in thickness, not be included in the overall length, and to be subject to the Measurer's approval."

Moved by Peter Vincent and seconded by Mike Hefford - passed.

*We noted that while we had no control over unmeasured boats, we should still make the fitting of bumpers a strong recommendation to other J owners.*

2) **August 2006:** - The Class Advisory Committee will recommend to the 2006 AGM that the 10 mm dimensioning of Bow Bumpers (as above) be removed and the operative clause "subject to the Measurers' approval" be strengthened to allow for more flexibility.

**August 14 2006 at the AGM** this recommendation was adopted so that for the Clause regarding bow bumpers; - Class Rules 1.2 is added to by way of an addition as follows:-

"That the fitting of a Bow Bumper on the Canterbury J Class be made mandatory. Such a bumper is not included in the overall length and is to be subject to the Measurer's approval."

Moved by Simon Ballantyne and seconded by Leon Blewett – passed

3) **October 2007** The AGM the Rules were further amended;

- a. Hull Numbering (*Peter Vincent/ Tom Arthur*): That Clause 2.1 to be added to, to reflect the requirement present on the Measurer's Certificate that the hull number should be clearly visible whenever the boat is measured. Passed
- b. Carbon Fibre tubing for booms: (*Leon Blewett/Lloyd Harman*) "That the Class Rules 3.2 and 5.1.1 be amended to allow for the use of carbon fibre tubing as boom spars and that the Measurement Form is altered accordingly. Passed

4) **November 2008** - The 2008 AGM approved a revision of the Class Rules as here published. Details of the revisions made are to be found in the Appendix to the 2008 AGM Minutes. This Revision was signed off for publication at a Committee Meeting of 28<sup>th</sup> October.

5) **October 2010** – The AGM reviewed and changed the Aft Keel Face measurement to 215MM max overall. A new B rig was accepted, thereby degrading the old B rig to C rig status and abandoned the old C rig.

6) **February 2014** – Special General meeting reviewed and changed to the following

Amend 3.2.4 to read

**Measurement bands in a colour that contrasts with the mast shall be displayed as per the sail and mast diagram and chart.**

Amend measurement chart and diagram to show H between top and bottom bands as

**1450mm – 1330mm – 1150mm.**

Amend chart and diagram to show I, between forestay band and bottom band as

**1310mm - 1200mm - 1025mm.** And name the bands from bottom up as **1, 2 & 3.**

Add to 4.1.1 Jib stay and / or jib halyard **shall intersect the mast below band 2.**

Amend 3.2.5 to: **Above the lower band 1, masts shall be of constant external circular diameter, without grooves for internal sail tracks. All fittings, holes, slots etc shall be ignored when considering the requirements of diameter. Internal stiffening and joining sleeves are permitted.**

Amend 3.2.6 to: **The centre of the mast / mast stub, shall pass through the deck between points 490- 540mm from the bow. The centre of deck stepped masts shall also be positioned between these two points on the deck.**

Amend 3.3.6 to **Below the lower band 1, any fitting or system may be used to step, support or control the position of the mast or boom.**

Delete 3.3.7

Replace 3.3.10 (3.3.9) with: **A fitting or system to mount the mast on the mast step.**

Amend 5.1.1 to **Construction; Booms shall be of constant external circular diameter, excluding fittings. Internal sail tracks shall not be permitted.**

Remove 3.2.5.

Amend rule 1.3 to. The Class shall consist of a fibreglass hull from the Class Association's official mould, a lead keel and trim weight from an approved mould, **a rudder as per specifications**, and rigs as per the sail plans with rigging that falls within the specifications. A bow bumper of a type approved by the Measurer shall be fitted and is not to be included within the overall length. Radio control is constrained to the use of two channels, being one rudder control and one coupled jib/main sail sheeting control.

Add to rule 2 heading, Hull, **keel, trim weight and rudder**

Note to add letter "s" to mould throughout document to cover NZ, UK and USA moulds

Amend rule 2.2 to. Dimension of the hull. **All measurements shall be taken from the outside of the fibreglass hull shell and shall exclude any protective strips or belting around the gunwales. If used, these shall have a maximum thickness of 3mm external to the hull shell.**

Maximum overall length:	1220mm
Beams as measured from the bow:	
at quarter length (305mm):	145-150mm
at half length (610mm):	215-220mm
at three quarter length (915mm):	185-190mm

Add new rule **2.3 Appendages. No appendages shall be attached externally to the boat which extend beyond or below the gunwale, excepting;**

**a) a bow bumper**

**b) attachments for the backstay**

**c) the rudder and its lower support**

Amend 2.3.1 to 2.4 **The keel and trim weight shall be produced only from the Class Associations official moulds or others approved by the Association. No materials other than lead shall be used.**

Amend 2.3.2 to 2.5 **The keel shall be bolted flush to the bottom of the keel stub and may be prepared and filled to provide a smooth underwater finish. No other additional weight or spacers shall be inserted between the keel stub and the keel. No additional weight in any form shall be inserted internally between the keel stub and the wooden floor.**

2.6. **The dimension of the stern post back edge shall be a maximum of 215mm. This shall be measured along the stern post from: the lower edge of the keel (lower rudder support included) to the intersecting lines of the hull.**

Amend rule 2.3.3 to 2.7 **The trim weight shall have a fixing hole of 8mm diameter centred 40mm (plus or minus 3mm) from the wider end and central between either edges. It shall be bolted onto the front keel bolt and lie flat on the wooden floor with the tapered end facing forward and shall be visible and accessible for inspection. Fittings may be attached to the trim weight. It shall not otherwise be altered from its original supplied state.**

**Renumber current 2.3.4 as 2.8**

Amend 2.4 to **The Rudder profile shall not exceed the official pattern (see relevant page for pattern) the rudder post shall be included within this area for measurement purposes.**

**The rudder thickness shall not exceed 15mm. The rudder shall not be ballasted.**

2.10 **The rudder may be mounted using a lower fitting and shall lie parallel with the stern post with a gap not exceeding 4mm. The rudder lower fitting shall be no wider than the keel width at the attachment point.**

Add rule 2.6 **The dimension of the stern post back edge shall be a maximum of 215mm. This shall be measured along the stern post from; the lower edge of the keel (lower rudder support included) to the intersecting lines of the hull.**

The application of these new and revised rules are to commence with the next hull for sale number 257. Further discussion took place on this motion and there is no intention that boats numbered 1 - 256 should be disadvantaged by the changes. Boats numbering 257 and up are strictly under these new rules

7) **October 2014**, The 16<sup>th</sup> AGM ruled that rule 8.2 be added; reading that any alteration or replacement shall be subject to the current class rules.

8) **October 2015**, The 17<sup>th</sup> AGM added the Grandfather Clause 8.2

9) **October 2016**, Sail Identification rules changed and updated to follow Appendix E with a supplementary sheet showing details.

Sail plans changes to simplify and clarify. Sampling the leech line to split into quarters to get to horizontal measuring points abandoned to measuring vertically up from the tack and then across at 90 degrees.

Added to clause 2.5

If the supplied keel should be larger than the hull shell profile, it shall be reduced in size to conform to the hull shell. No altering of the hull shell is allowed.

**8) October 2017**, Clause 7 altered to read at least 3 digits from the hull number to be used as sail identification.

**9) October 2017**, Clause 7.2 Prefix & Suffix requirement removed.